

Order picking truck

Truck specifications					OSE250	OSE250P
Identification	1.1	Manufacturer			BT	BT
	1.2	Model			OSE250	OSE250P
	1.3	Drive			Electric	Electric
	1.4	Operator type			Stand on	Stand on
	1.5	Load capacity/rated load	Q	kg	2500	2500
	1.6	Load centre	c	mm	1200	1200
	1.8	Load distance, back of fork to bogie wheel centre, raised/lowered support arms	x	mm	886/957	886/957
	1.9	Wheelbase, raised/lowered support arms	y	mm	2088/2159	2088/2159
Weight	2.1	Service weight without battery, short/long chassis		kg	765/897	765/897
	2.2	Axle load, with load, drive/castor/fork wheels short chassis long chassis		kg	833/670/2223	833/670/2223
				kg	894/800/2243	894/800/2243
	2.3	Axle load, without load, drive/castor/fork wheels short chassis long chassis		kg	480/270/250	480/270/250
				kg	500/300/270	500/300/270
	Wheels	3.1	Drive / castor / fork wheels			Vulkollan
3.2		Wheel size, front		mm	Ø 250 x 75	Ø 250 x 75
3.3		Wheel size, rear		mm	Ø 85 x 74	Ø 85 x 74
3.4		Additional wheels, dimensions		mm	Ø 150 x 78	Ø 150 x 78
3.5		Wheels, number front / rear (x =driven wheels)			1x+ 1/4	1x+ 1/4
Dimensions	4.2.1	Overall height	h_{15}	mm	1277	1277
	4.4	Lift Lift height	h_3	mm	150	150
			h_{23}	mm	235	235
	4.8	Stand height, min./max.	h_7	mm	138	138/980
	4.15	Height, fork lowered	h_{13}	mm	85	85
	4.19	Overall length, short/long chassis	l_1	mm	2488/2574	2488/2574
	4.20	Length to face of forks, short/long chassis	l_2	mm	1338/1424	1338/1424
	4.21	Overall width	b_1	mm	790	790
	4.22	Fork dimensions	s/e/l	mm	50/180/1150	50/180/1150
	4.25	Width over forks	b_5	mm	450-685	450-685
	4.31	Ground clearance	m_1	mm	55	55
	4.34	Aisle width for pallets 800 x 1200 lengthways	A_{st}	mm	2739	2739
	4.35	Turning radius, short/long chassis	W_a	mm	2301/2387	2301/2387
	4.44	Clear width driver compartment entrance	l_{24}	mm	450	450
Performance data	5.1	Travel speed, with/without load		km/h	8,0/12,0	8,0/12,0
	5.2	Lift speed, with/without load		m/s	0,067/0,094	0,067/0,094
	5.3	Lowering speed, with/without load		m/s	0,06/0,06	0,06/0,06
	5.8	Max. gradeability, with/without load ¹⁾		%	8/13	8/13
	5.10	Service brake			Electromagnetic	Electromagnetic
Electric motor	6.1	Drive motor rating S2 60 min		kW	2,8	2,8
	6.2	Lift motor rating S3 7%		kW	2,0	2,0
	6.4	Battery voltage, nominal capacity K_5		V/Ah	24/310-620	24/310-620
	6.5	Battery weight, min./max.		kg	239/501	239/501
	6.6	Energy consumption acc to VDI cycle ²⁾		kWh/h		
Other	8.1	Type of drive control			BT Powerdrive	BT Powerdrive
	8.4	Sound level at the driver's ear according to EN 12 053		dB(A)	63	63

1) Measured according to company standard.

2) Contact your supplier for information.

All data are based on table configuration. Other configurations may give other values.

Truck performance and dimensions are nominal and subject to tolerances.

BT products and specifications are subject to change without notice.

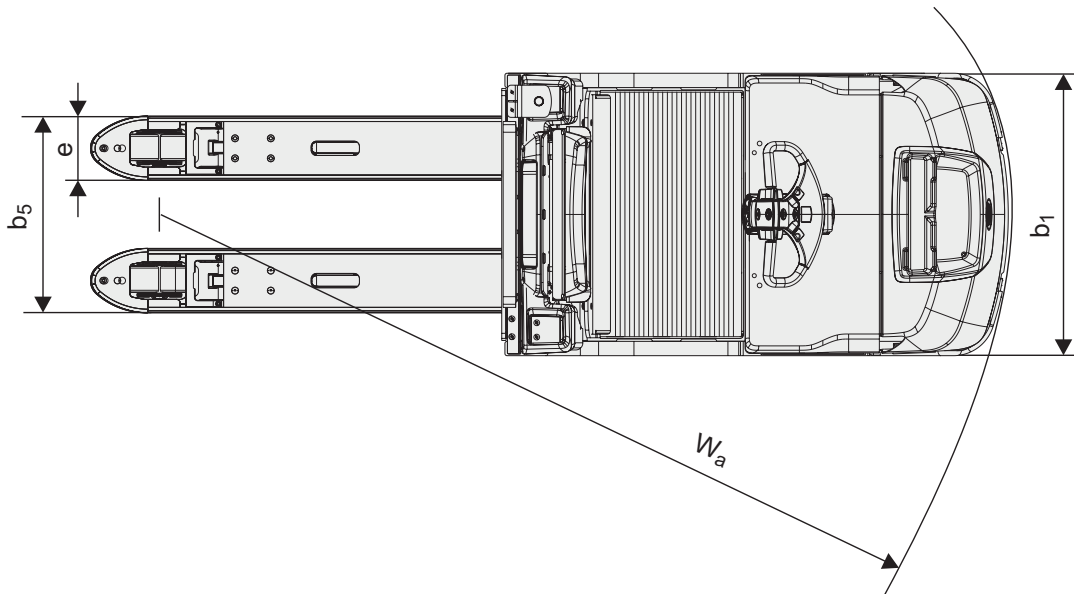
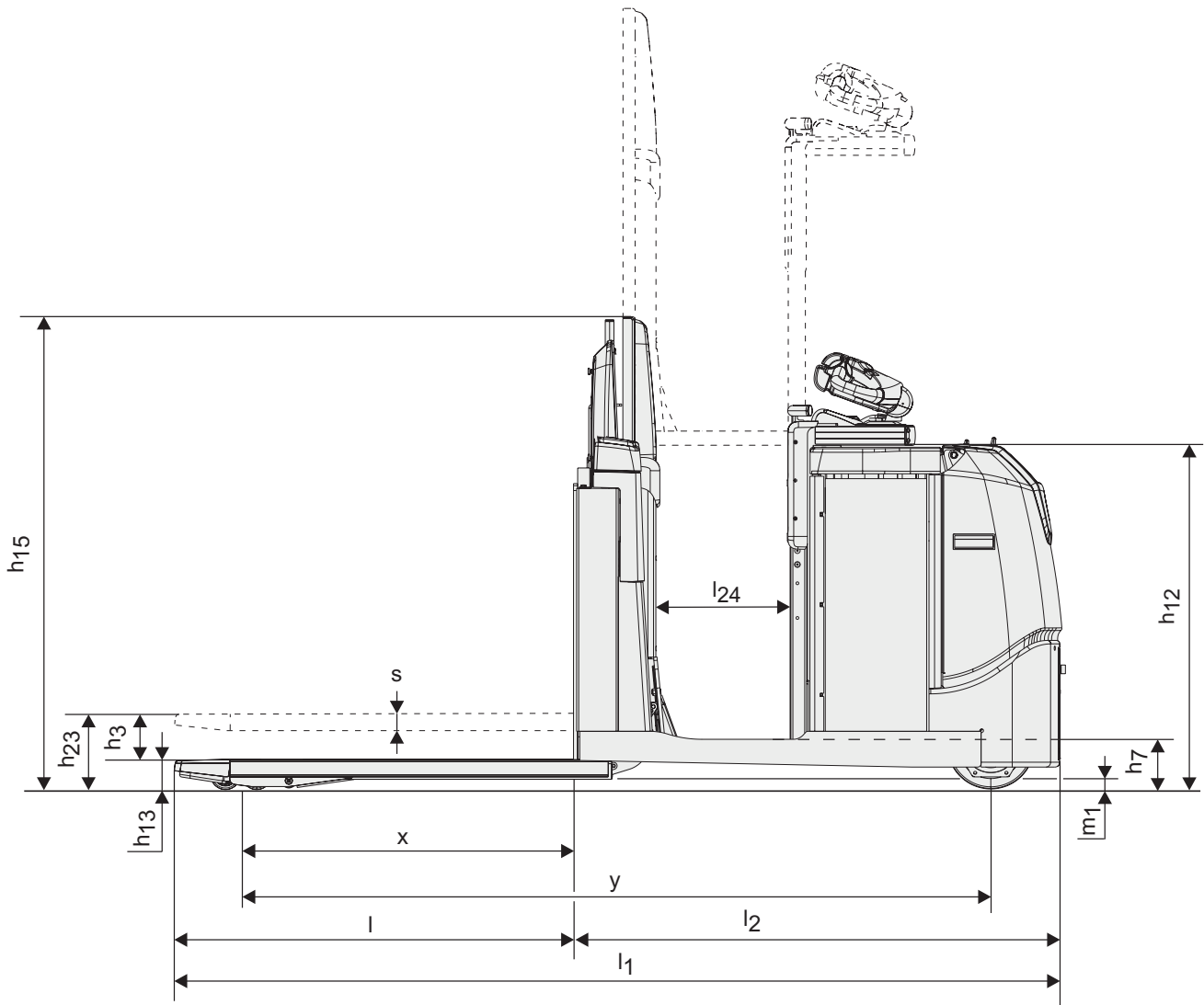

Truck features:

- High performance models
- BT E-man steering concept
- Low step-in
- BT Powerdrive system
- Sensi-platform lift
 - including elevating controls (P-model)
- Integrated shrink film holder
- Streamlined administration
 - E-bar concept (option)
- Frequency adapted suspension (option)