

XMX Series

75 - 1,000 scfm

System Flow Controllers



GD
GARDNER DENVER™

Experience Proven Results™

Stop Wasting Air

- ▶ Reduce Energy Consumption
- ▶ Improve Productivity
- ▶ Enhance Air Compressor Life
- ▶ Minimize Maintenance Costs



Source: US Dept of Energy/Compressed Air Challenge

XMX Savings Example – The 10/7 Equation

Reducing plant pressure by 10 psi results in a 7% energy consumption reduction. Installing an XMX Controller, along with adequate compressed air storage, allows compressed air to be stored at a higher pressure while delivering consistent, low-pressure air to an application.

A 15 HP compressor running 3,000 hours per year at \$0.10 per kW = \$3,300 annual power consumption.

What is the XMX System Flow Controller?

The XMX Series is a balanced flow controller which provides an economical and reliable single point of control when it comes to controlling the air pressure delivered to your operation. As opposed to a simple regulator that cannot deliver air volume above its set point, the XMX Series is designed to recognize and react to increases in flow demand.

Why Use an XMX System Flow Controller?

Regardless of the care that is taken when an air system is designed and installed, it is still going to have leaks and waste. When the working pressure delivered to that system is reduced, the volume of air lost to those leaks and waste is dramatically reduced. Reducing the amount of lost air results in less run time for an air compressor. The lower power consumption and decreased maintenance costs associated with less air compressor run time are direct improvement to the bottom line.

	POWER CONSUMPTION REDUCTION	SAVINGS
psi Reduction 20	14%	\$462
psi Reduction 40	28%	\$924
psi Reduction 70	49%	\$1,617

Features & Benefits

- Unit can be ordered for left to right or right to left flow to meet the needs of the installation
- Balanced valve design provides immediate response to changes in air demand
- NPT thread allows unit to connect easily into new or existing piping systems
- Nitrite seals for high level of chemical resistance
- Dual stainless steel gauges allow easy reference to both inlet and outlet pressures
- Tamper proof dial is centrally located for quick adjustment and easy calibration



Technical Data

Part Number	Flow Direction	Max Flow scfm	Max Inlet Pressure psig	Control Range psig	Max Operating Temp. Range	Connection Size (Female)	Sensitivity	Repeatability
XMx75-RL	Right to Left	75				1/2" NPT		
XMx75-LR	Left to Right	75				1/2" NPT		
XMx200-RL	Right to Left	200	300	0 - 160	-4° F to 176° F -20° C to 80° C	1" NPT	0.2% of full span	± 0.5% of full span
XMx200-LR	Left to Right	200				1" NPT		
XMx1000-RL	Right to Left	1000				2" NPT		
XMx1000-LR	Left to Right	1000				2" NPT		

Part Number	A	B	C	D	E	Weight
XMx75-RL					1.89"	8.40 lbs.
XMx75-LR					1.89"	8.40 lbs.
XMx200-RL	8.11"	7.28"	8.57"	7.36"	2.21"	10.45 lbs.
XMx200-LR					2.21"	10.45 lbs.
XMx1000-RL					2.78"	14.65 lbs.
XMx1000-LR					2.78"	14.65 lbs.

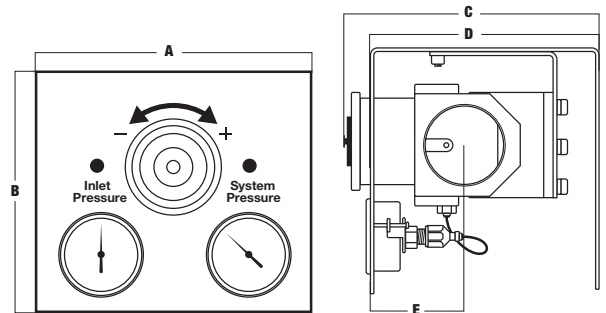

Other Innovative Products



FIL Series High Efficiency Filters

A full range of filters 20–21,250 cfm; coalescing, particulate, and activated carbon for the removal of water, oil, and particulates from compressed air.



DS2 Series Evacuator Drain Valves

A full family of zero air loss, energy efficient demand drains. Ruggedly designed to effectively and reliably prevent moisture damage to dryers, air tools, gauges, and other critical components.



RNC Series Refrigerated Dryers

A full line of high quality refrigerated dryers with features and benefits unmatched by the competition. Designed to produce dew points as low as 38° F in compressed air.



DGH Series Desiccant Dryers

A complete line of desiccant dryers for the removal of water vapor in compressed air to dew points as low as -100° F.

Gardner Denver®

www.GardnerDenverProducts.com

Gardner Denver, Inc. 1800 Gardner Expressway, Quincy, IL 62305
www.contactgd.com/compressors
 866-440-6241

©2013 Gardner Denver, Inc. Printed in U.S.A. ESP-XXM-SFC 1st Ed. 5/13



 Please recycle after use.